

# EZ-TRAP®

U.S. Patent Numbers 5,069,042 5,522,229

## 3/4" Combo Kit Condensate Trap & Overflow Switch

**New!** Compact Modular  
Switch Assembly

Float Switch Assembly	(1)
1" x 3/4" Slip Street Ell	(1)
3/4" Male Adaptor	(1)
72" Modular Cable	(1)
Red/Blue Label	(1)
3/4" Standard Trap	(1)
3/4" Cross	(1)
3/4" Tee	(1)
Red Caps	(3)
Yellow Cleaning Label	(1)
Cleaning Brush	(1)

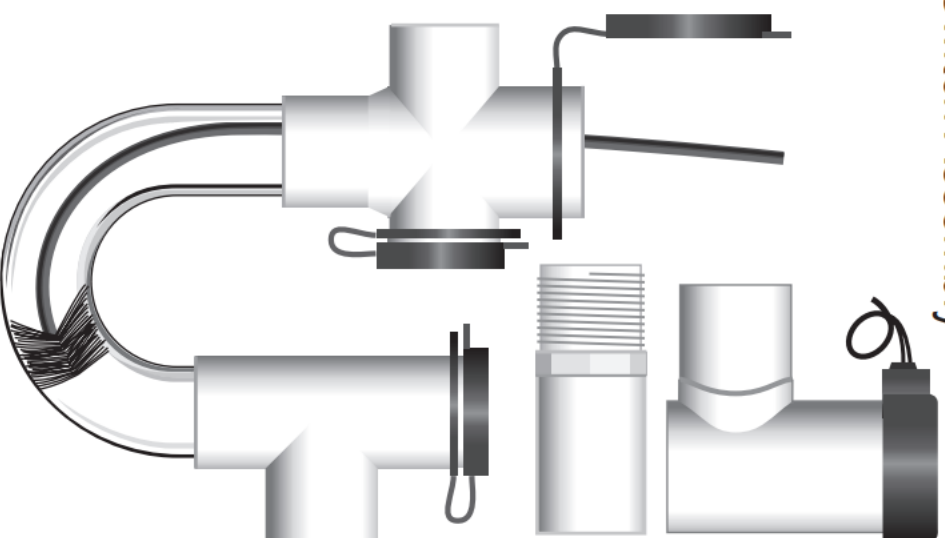

**3 YEAR WARRANTY.** The manufacturer disclaims all implied and express warranties, including the implied warranty of merchantability and the implied warranty of fitness for a particular purpose, except as follows: The EZ-Trap condensate trap or overflow switch purchased by you is **unconditionally warranted** to be free from defects in material and workmanship under normal use for a period of three (3) years from date of purchase, providing it is installed and operated strictly in accordance with manufacturer's installation instructions. If the product is found to be defective or otherwise fails in normal use, you may return it for replacement. All freight charges for the return of the product shall be borne by you. The manufacturer will pay outgoing freight charges for the replacement product. Defective products returned to the factory prepaid will be repaired or replaced free of charge. Replacement product will, to the extent such product is then available in manufacturer's inventory, be of similar type, color and kind. Manufacturer retains the right to substitute product if replacement product does not conform in terms of color, type and specifications to the original product, if no longer available. This warranty does not cover replacement labor or any cost, claim or incident to any defect nor does it cover freezing or any other consequential damages. The sole liability of the manufacturer under this warranty is limited to the replacement of defective product. Product damaged by improper use, accident, neglect, alteration, abuse or improper installation is excluded from this warranty.

**RectorSeal®** 2601 Spenwick Drive - Houston, TX 77055  
ph: 713.263.8001 - 800.231.3345 fax: 713.263.7577 - 800.441.0051  
[www.rectorseal.com](http://www.rectorseal.com) - Like Us on Facebook

961831

# Installation Instructions

(EZT626)

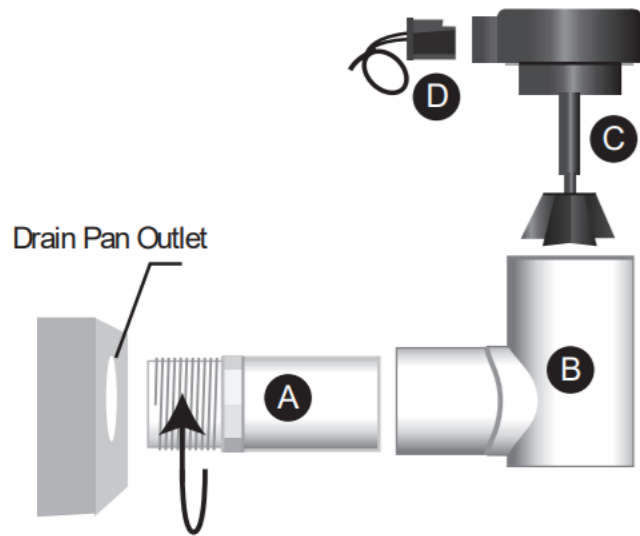

## Switch Assembly Instructions

1. Screw Adaptor (A) into 3/4" drain pan overflow outlet.
2. Glue Street EII (B) to Adaptor (A). Assembly must be plumb.
3. Press fit Float Switch Assembly (C) into 1" opening at top of Street EII (B). DO NOT USE GLUE. Check that Actuator Arm and Float moves freely inside Inlet Tee.
4. Press plug end of Modular Cable (C) into Float Switch Assembly (B)
5. Attach warning & cleaning labels to condenser and airhandler as indicated.

## Important:

Install in strict accordance with RectorSeal instructions as well as all applicable local plumbing, drainage and electrical codes.

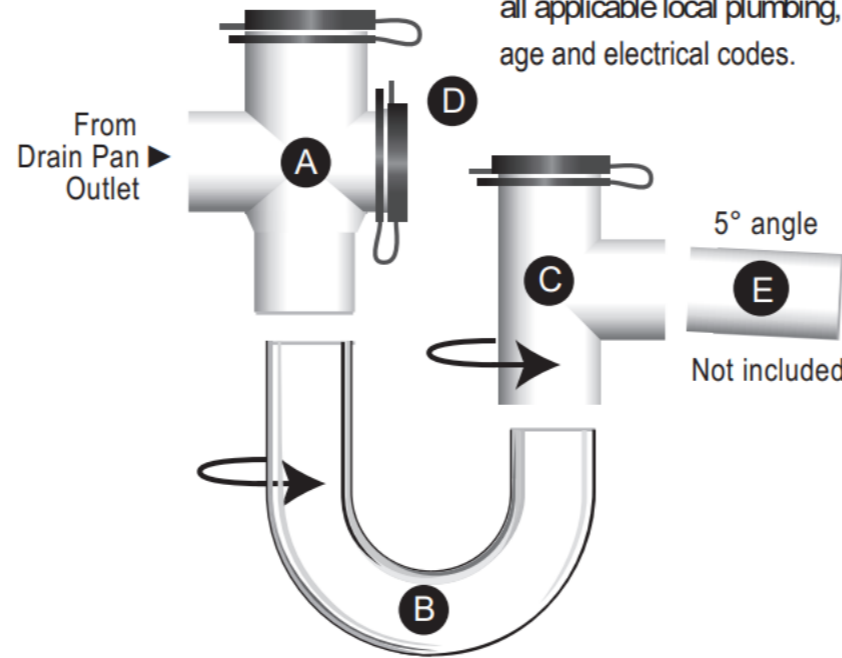

## Trap Assembly Instructions

1. Dry fit, and mark components, rotating U-Bend (B) and Cross Tee (C) to required angles for installation.
2. Glue components (A thru C) using dry fit markings. Then glue assembly into Drain Pan Line
3. Glue Drain Line (E) into center leg of Outlet Tee (C). Drain Line must exit building with at least a 5° angle.
4. Check that Red Caps (D) are tightly secured.
5. Attach cleaning label as indicated.

**Note:** Insulation is required when trap is installed in unconditioned space where sweating can occur.

## Wiring Instructions

1. Turn off power at main panel before opening unit and working on electrical system.
2. An inline fuse is necessary to protect the 24V circuit.
3. Connect Float Switch using wiring diagram. (below)
4. Test system for proper operation by lifting float.

**Note:** Wiring diagram shown cuts power to thermostat when float switch operates so entire AC unit stops operating. To inhibit mold growth during long absences, connect terminals into yellow cooling circuit so when float switch operates, condenser will switch off but fan will continue running.

